

STK-010 BSA: B25, B40, B44, B50, C15, C12T, Royal Enfield Bullet | Matchless 350

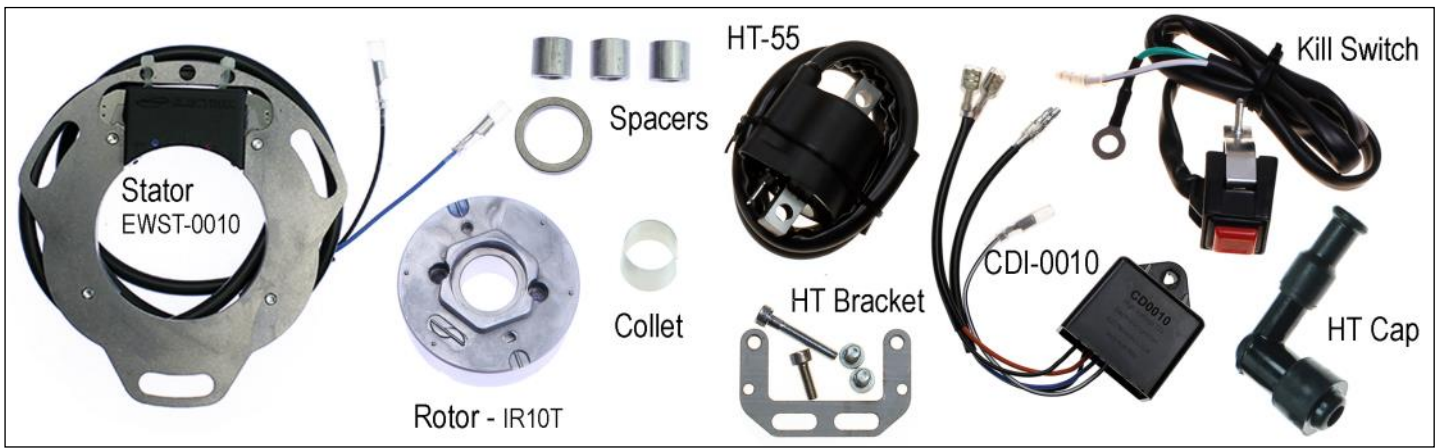

PRODUCT FEATURES

- Self generating CDI ignition with electronic advance, developed for BSA singles, for easy starting and maximum performance.
- Fully compatible for operation within the engine oil.
- Replaces the original Lucas alternator - points and distributor are not required.
- Keyless taper locking rotor system.

Fitting Instructions

- Step 1 Remove the original stator & rotor from left hand cover.
- Step 2 **Fitting the rotor:** The rotor is tightly held on the crankshaft by the tapered collet system. First fit the collet on the crankshaft pushing it to stop against the primary drive pinion, then locate the rotor, spacer and locking unit. See fig 3. Don't fully tighten the rotor yet, allowing it to rotate freely on the crankshaft.
- Step 3 Place the 3 spacers provided on the studs, leaving in position the original spacers and chain tensioner.
- Step 4 Fit the new stator as shown (see fig 2) with stainless steel retaining plate outermost.
- Step 5 **See wiring diagram overleaf.** Feed cables through crank case. Connect stator cables to the black & blue cables from the CDI unit. Locate HT coil (a bracket is included to help fit the coil), and connect the orange & black cables from the CDI to the HT Coil. The remaining Black/white cable from the CDI is for connecting to a kill switch. When connected to earth the engine will stop, see wiring diagram overleaf.
- Step 6 **Easy timing setup:** Set piston to Top Dead Centre (TDC) and align the Blue mark on the stator with the Blue mark on the rotor. Do this by rotating the rotor on the crankshaft. When positioned lock the rotor by tightening the nut.
- Step 7 Tighten retaining nut to 30 ft lbs torque (less than original setting) for the stator ensuring that there is an even air gap with the rotor.
- Step 8 Re-check timing is correct, move stator to adjust if needed.

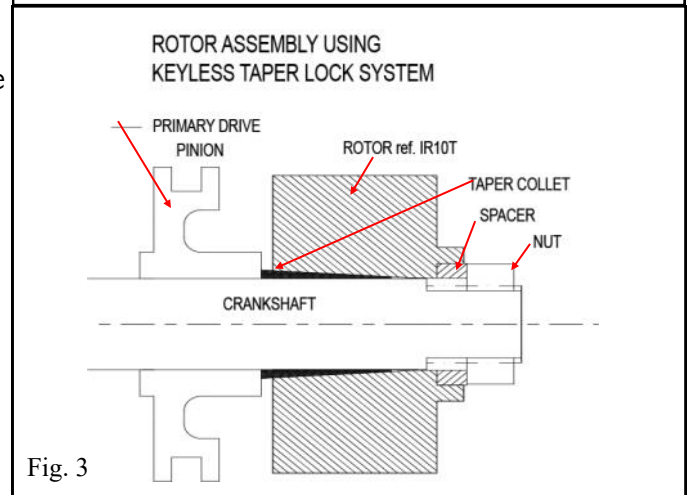
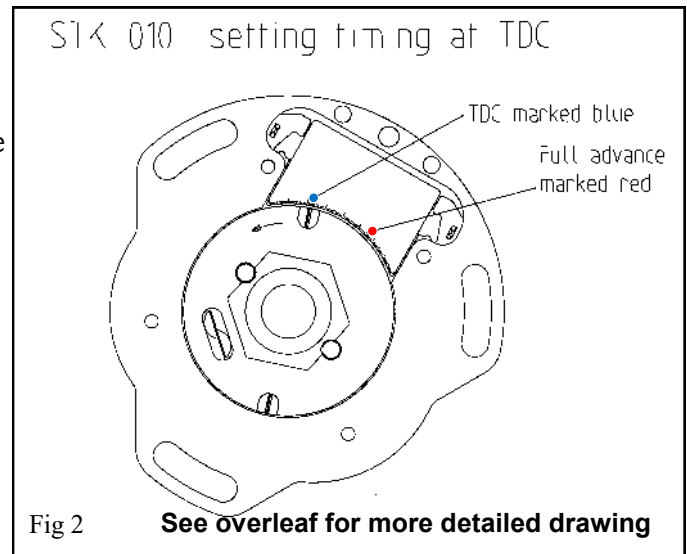
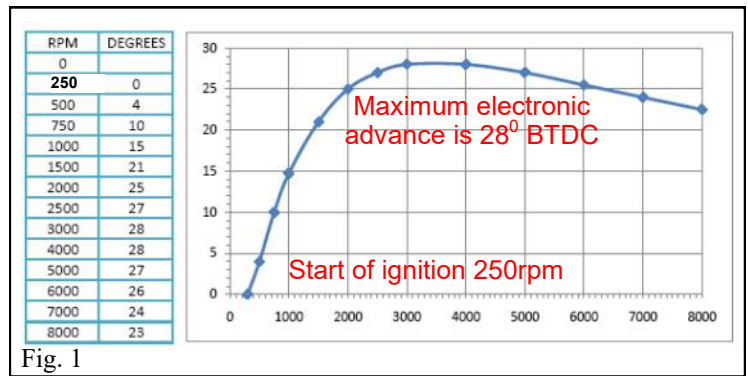

STK-010 BSA: B25, B40, B44, B50, C15, C12T, Royal Enfield Bullet | Matchless 350



NOTE: The engine timing settings overleaf are intended as a guide only, engines with different states of tune or running on methanol may require a different set-up.

Setting the timing :	Model	C15/B40	B25	B44	B50
Full advance	degrees	35.5°	37°	28° - 31°	34°
Before TDC	mm	6.5mm	7.0mm	5.3 - 6.4mm	7.7mm

Special Note for B44: Full advance 28° for 1967 & earlier round barrel models. 29° - 31° for 1968 on square barrel models.

